

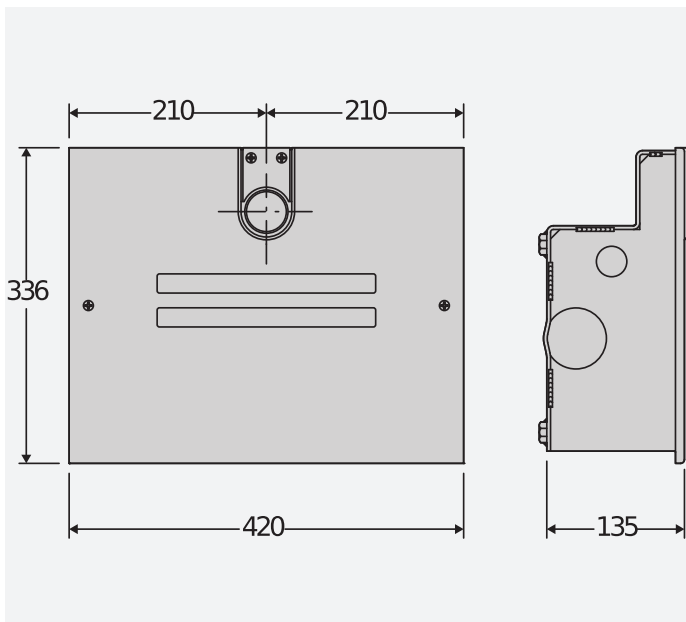

Complete range of irreversible underground electromechanical operators for swing gates up to 400 kg and 3.5 m long. The magnetic limit switch system (BT) guarantees maximum precision and reliability in any climatic conditions.

DIMENSION (MM)



Technical features

	ELI 250 N BT
Control unit	THALIA
Board power supply	
Motor voltage	24 V
Power input	175 W
Max. width of door/gate wing	3.5 m
Max. weight of door/gate wing	400 kg
Maximum angle	120 °
Cycle time	15 s
Type of limit switch	Magnetic
Slowdown	Yes
Locking	Mechanical
Release	Lever or lever with personalised key
Impact reaction	D-Track
Frequency of use	intensive
Protection rating	IP67
Environmental conditions	-20 ÷ 50 °C



		Description	
P930125 00001	ELI 250 N BT	In-ground irreversible electromechanical operator 24 V for swing gates weighing up to 400 kg and 3.5 m long. Limit switch Magnetic.	 U-Link

THALIA: Control panel with display for one or two 24V electromechanical operators for swing gates.

D113745 00002 - THALIA - Built-In



- Control panel with display for one or two 24V electromechanical operators for swing gates
- Application: control panel with display for one or two 24V electromechanical operators for swing gates
- Board power supply: 230V single-phase
- Operators power supply: 24Vdc 180W max each operator
- Main features: new standard colour removable terminal blocks, simplified scenario-based programming with display and integrated dual-channel receiver, D-Track anti-crushing system, slowdown during opening and closing and electronic self-learning
- Main functions: automatic re-closing, fast closing, partial opening, deadman feature
- Compatibility: LIBRA C MA, LIBRA, LIBRA R, LIBRA MA R

RECOMMENDED ACCESSORIES

	D113747 00002 - THALIA P Control panel for one or two 24V electromechanical and hydraulic operators for swing gates with electric lock management, for highly complex systems.		N733397 - BTCF 120 E Foundation box with levers for ELI 250 N BT, ELI 250 N, ELI 250 N V. Release not supplied.
	N733398 - BTCF 120 E INOX Stainless steel foundation box with levers for ELI 250 N BT, ELI 250 N, ELI 250 N V. Release not provided.		N733392 - SCC Release for ELI 250N and SUB BT with lever key.
	N733502 - SCP Release for ELI 250 and SUB BT with personalized key.		P125020 - BBT BAT Set of backup batteries for THALIA and THALIA P.
	D111761 - ME BT Control board for 24Vac solenoid lock for 24V automation systems.		

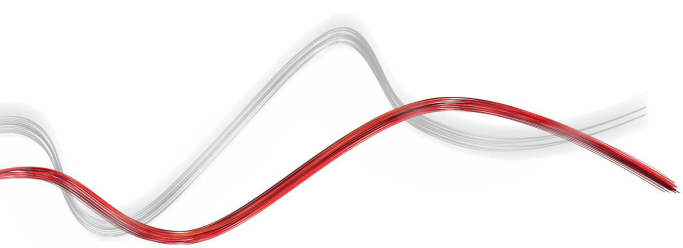

www.bft-automation.com

INFORMATIVA A TUTELA DEI DIRITTI DI PROPRIETA' INDUSTRIALE E INTELLETTUALE DI BFT. BFT S.p.A. tutela i propri diritti di proprietà industriale attraverso il deposito di marchi, brevetti, modelli e design. La proprietà intellettuale di BFT S.p.A. è tutelata a norma della legge sul diritto d'autore. BFT S.p.A. tutela inoltre il proprio know-how adottando misure di protezione delle informazioni tecniche e commerciali inerenti la propria azienda e i propri prodotti. Tutti i prodotti presenti in questo catalogo sono MODELLI ORIGINALI BFT e BFT S.p.A. è la sola autorizzata a produrli e commercializzarli in tutto il Mondo. Tutti i nomi commerciali attribuiti ai prodotti presenti in questo catalogo sono di titolarità di BFT S.p.A. che è la sola autorizzata al loro uso in relazione alla relativa categoria merceologica. I CONTRAFFATTORI VERRANNO PERSEGUITI A NORMA DI LEGGE SIA IN SEDE CIVILE CHE PENALE. IL TUTTO A GARANZIA NON SOLO DEL PATRIMONIO INTELLETTUALE DI BFT, MA ANCHE A TUTELA DEI CLIENTI CHE ACQUISTANDO PRODOTTI BFT ACQUISTANO PRODOTTI ORIGINALI FRUTTO DI STUDI E PROGETTI INTERNI ALLA SOCIETA' BFT.