

770

FAAC

underground electro-mechanical operator for residential swing-leaf gates with single-leaf length of 3.5 m and max weight of 500 kg



A NEW TECHNOLOGICAL THRESHOLD

The FAAC underground system is the new way of opening and closing residential gates with leaves of up to 3.5 metres in length. As is completely invisible, it does not change the appearance of the gate.

ELECTRONIC SAFETY

Anti-crushing protection is ensured by an electronic device installed on the 452 MPS - 455 D equipment, which directly controls drive torque. In case of an emergency, manual operation is assured by a special lever release system with customised key, accessible from both inside and outside.

TOTAL EFFICIENCY

The FAAC 770 model design includes a casing to house automated systems for gates of up to 500 kg per leaf, making installation simple. Corrosion-proof coating highly resistant to atmospheric agents, absolute weather-proofing, operator in protection class IP 67 all these are plus points in addition to the undoubted advantages of long-life and safety assured by FAAC's electro-mechanical technology.

LOW MAINTENANCE

When maintenance is necessary, the operator can be simply removed from the foundation box without removing the gate leaf.

SPECIFICATIONS

Non-reversing **electro-mechanical concealed operator** for swing-leaf gates • Leaf max length 3.5 m and max weight 500 kg • Max use frequency 20 cycles/hour • Underground installation • Leaf opening inwards or outwards • Max opening angle 110° or 140° (with optional kit) • Max torque 330 Nm • Transmission-shaft angular velocity 6°/s • Electric motor power supply 230 Vac (+6% -10%) - 50 (60)Hz • Electric motor power 380 W • Thermal protection at 140°C built into motor winding • Protection class IP67 • Operating ambient temperature -20°C + +55°C • Operator body with corrosion proof treatment • Reduction ratio of motor/transmission shaft 1.450:1 • Motion transmission levers • Leaf deceleration by unequal levers • Grease lubrication.

Casing

Casing in steel with cataphoresis treatment • Cover in stainless steel • Leaf support bracket with key-operated lever release system • Overall dimensions 430x308x156 mm (LxWxH)

FAAC
Simply automatic.

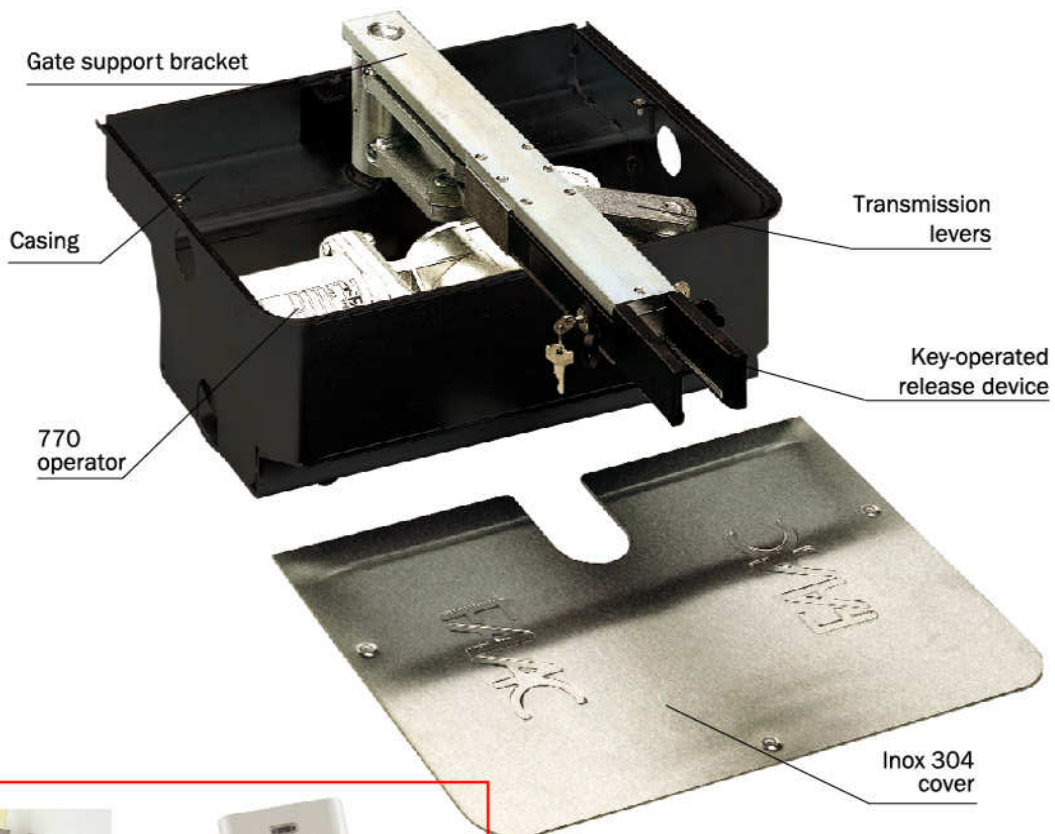

NEW Carrier case in stainless steel with release system (Optional)



Two-channel long range transmitter XT2 433
Four-channel long range transmitter XT4 433 (Optional)

Dimensions

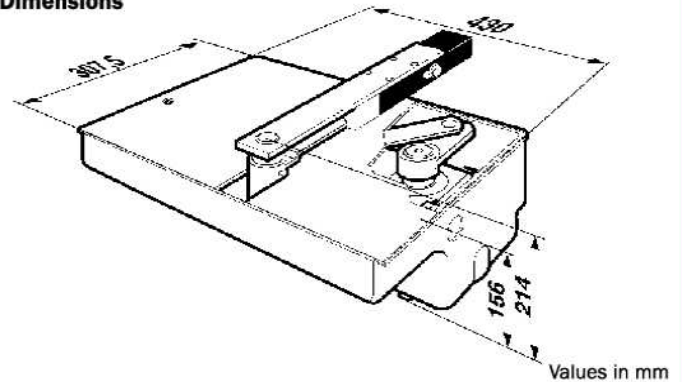

INSTALLATION LAYOUT

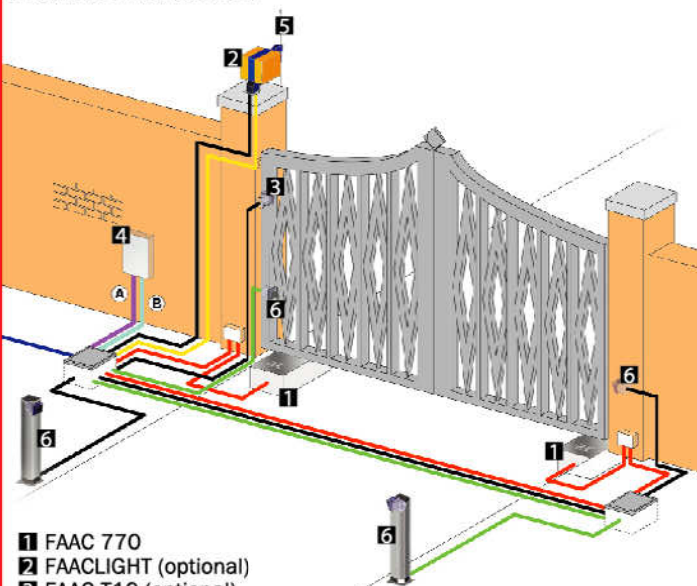

- 1 FAAC 770
- 2 FAACLIGHT (optional)
- 3 FAAC T10 (optional)
- 4 FAAC 452 MPS/MINIDEC DS
- 5 FAAC PLUS 1 433
- 6 FAAC FOTOSWITCH (optional)

Low voltage cabling		Power cabling (230V)	
A	4 cables 3x0,5	B	2 cables 3x1,5+T
	2 cables 2x0,5		1 cable 2x1,5+T
			1 cable 2x1,5

N.B: Cable diameters in mm²

Technical specifications	770-230v	770-24v
Power supply	230 Vac (+6%-10%) 50-(60)Hz	24 Vdc
Absorbed power	380 W	70 W
Torque	0+330 Nm	300 Nm
Absorbed current	1.7 A	3 A
Motor rotation speed	1450 rpm	
Electric motor	Single-phase, bi-directional	
Thermal protection on motor winding	140 °C	
Pinion angular velocity	6°/s	
Operating ambient temperature	-20 °C + +55 °C	
Weight	14 kg	
Leaf opening max angle	110° (140° with optional kit)	
Deceleration	by unequal levers	
Protection class	IP 67	

Technical specifications of casing

- in steel with cataphoresis treatment
- cover in stainless steel
- leaf support bracket with key-operated lever release system