



# NABCO Automatic Door Sliding Door NAL & NLC



## Nabtesco

Nabtesco Corporation Accessibility Innovations  
Company  
JA Kyosai Bldg. 7-9, Hirakawacho 2-chome Chiyoda-ku  
Tokyo 102-0093, Japan  
Tel: 81-3-5213-1156

NABCO Autodoor (Beijing) Co., Ltd.

2F Liandong International Industrial Park, no.15  
Jingsheng South 4th Street, Tong Zhou District, Beijing  
101102 P.r China Tel: 010-6050-3858  
Email: liuyanban@nabco.cn

<https://nabco.nabtesco.com/en/>

NABCO Auto Door (Beijing) Co., Ltd Shanghai Branch  
No.388, Pudian Road, Pudong New Area, Shanghai  
Tel: 021-33538556

NABCO Auto Door (Beijing) Co., Ltd Guangzhou Branch

460BA, R&F Yingkal Plaza, No16 Huaxia Road, Tianhe  
District, Guangzhou, China.  
Tel: 020-28395803



<http://www.nabco.cn>



获得ISO9001, ISO14001, ISO45001认证



## Content

Advantages of NABCO Automatic Swing Door	02
Overhead Concealed Heavy Duty Swing Door GT-8300	03
Surface Mounted Heavy Duty Swing Door GT-8400	04
Surface Mounted Swing Door GT-10/GT-20B	05
Surface Mounted/Overhead Concealed Swing Door GT-660	06
Underground Concealed Swing Door GT-610/GT-620	07
Overhead Concealed Swing Door GT-650	08
Manual Balance Door GT-5	09
Automatic Balance Door GT-8300BD	10
Accessories	11
Project References	12
Operation and Maintenance	17
History	18

## Opening a bright future for everyone

### 01 Comprehensive Solutions

- GT-10 Middle Duty Swing Door (Surface Mounted)  
Applications: Boutique hotel guest rooms, high-end retail stores, etc.
- GT-610 Middle Duty Swing Door (Underground)  
Applications: Large venues, airport terminals, etc.
- GT-660 Middle Duty Swing Door(Surface Mounted/Overhead Concealed)  
Applications: Schools, hospitals, shopping malls, office buildings, entrance doors, rehabilitation centers, etc.
- GT-650 Middle Duty Swing Door (Overhead Concealed)  
Applications: High-end office buildings, hotel guest rooms, etc.
- GT-20B Heavy Duty Swing Door (Surface Mounted)  
Applications: Office doors in commercial buildings, bank branches, etc.
- GT-620 Heavy Duty Swing Door (Underground)  
Applications: Large venues, airport terminals, etc.

#### Light Duty

#### Breakout Function

- GT-8300 Heavy Duty Swing Door (Overhead Concealed)  
Applications: High-end office buildings, main entrances of large shopping malls, etc.
- GT-8400 Heavy Duty Swing Door (Surface Mounted)  
Applications: Entrances of high-end commercial complexes, five-star hotel lobbies, etc.

#### Heavy Duty

#### Special Functions

- GT-5 Manual Balance Door Applications: Public places with heavy traffic, buildings with a stack effect, areas prone to typhoons, wind, and snow.
- GT-8300BD Automatic Balance Door Applications: Large shopping malls and centers, high-end brand stores, airport terminals.

### 02 Technology and Quality Advantages



#### Global Technology Accumulation

- Originating in Japan in 1956, NABCO has continuously expanded and innovated in the United States, Switzerland, China, and other regions, growing into a global entity with 70 years of experience in automatic door R&D.
- Core components are imported (American/Swiss series), certified to ANSI 156.10, UL/ULC/CSFM, ensuring operational stability.

#### Leading Safety Performance

- Enables breakout function, improving passage efficiency and safety performance.
- Manual opening function during power outages, buffer closing design, suitable for high-security scenarios such as medical and financial facilities.

#### Efficient and Energy-Saving Design

- Low-energy drive system (e.g., GT-710 model power consumption ≤560W), intelligent opening and closing control reduces loss of conditioned air, achieving over 30% energy savings compared to traditional doors.
- Capable of one million opening cycles, extending maintenance intervals.

# GT-8300



## Overhead Concealed Heavy Duty Swing Door

### Product Features

- American imported equipment, quality assured.
- Powerful performance, superior typhoon resistance.
- Concealed equipment with no exposed arm when the door is closed, enhancing aesthetics.
- Microelectronic controller for smooth and efficient operation.
- Bi-parting configuration allows one leaf to open inward and the other outward automatically. In an emergency, both leaves can be manually opened simultaneously in the breakout direction.
- Conforms to ANSI Standard 156.10, certified by UL, ULC, and CSFM in the United States.

### Specifications

Item	GT-8300 2 units	GT-8300 1 unit
Door Opening Type	Bi-Parting(Double leaf * 90° opening)	Single Leaf (Single leaf * 90° opening)
Door Leaf Weight(kg) × Leaves	Standard	150×2
	Heavy-Duty	(151~250) ×2
	Standard	1841 and above
Drive Unit Length (mm)	Transformer external (controller concealed)	1637~1840
	Transformer and controller external	1359~1636
Single Leaf Area: DW×DH (m <sup>2</sup> )	MAX4.5	
Door Leaf Thickness: DT (mm)	44	
Function During Power Outage	Manual Open - Automatic Close	
Unit Dimensions	W940×H152×D148	
Unit Surface Color	Silver	
Average Opening/Closing Speed	~35 degrees/sec	
Required Power Supply Capacity	AC 220V·5A	AC 220V·2.5A

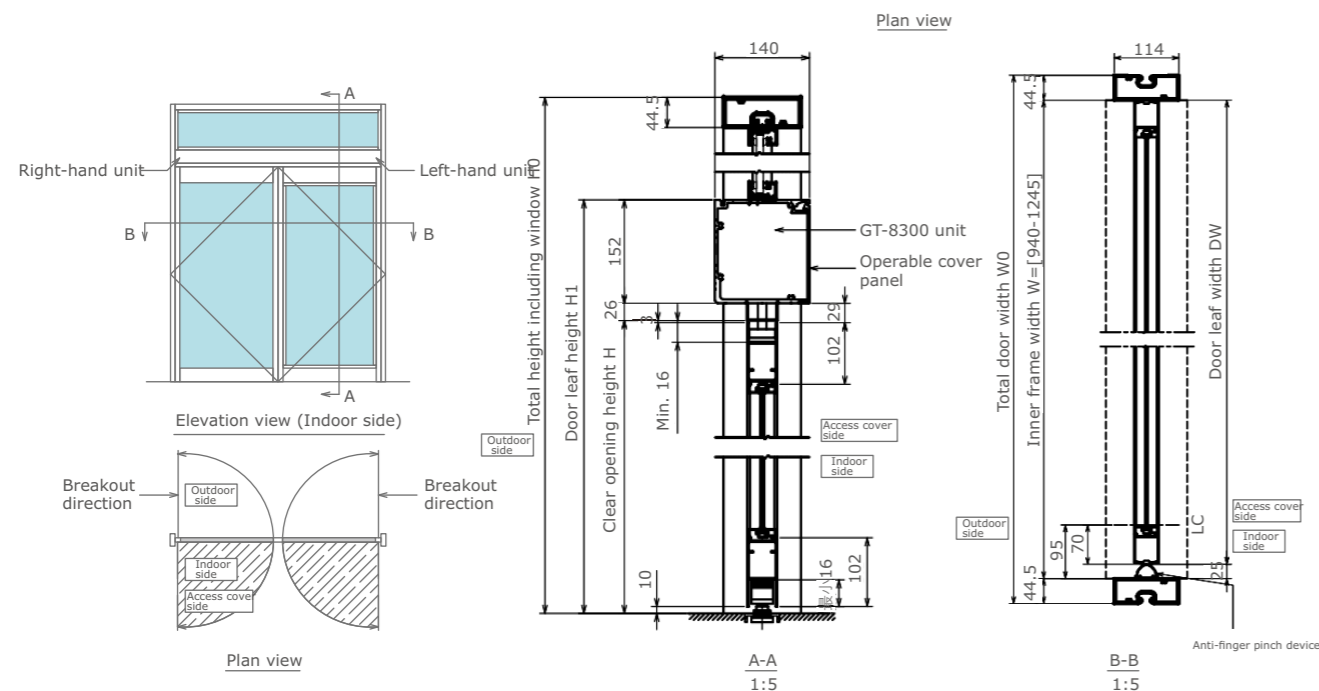

# GT-8400



## Surface Mounted Heavy Duty Swing Door

### Product Features

- American imported equipment, quality assured.
- Powerful performance, superior typhoon resistance.
- Can be easily converted to an automatic swing door without modifying the existing manual door leaf; very simple installation.
- Microelectronic controller for smooth and efficient operation.
- Bi-parting configuration allows one leaf to open inward and the other outward automatically. In an emergency, both leaves can be manually opened simultaneously in the evacuation direction.
- Conforms to ANSI Standard 156.10, certified by UL, ULC, and CSFM in the United States.

### Specifications

Item	GT-8400 2 units	GT-8400 1 unit	
Door Opening Type	Bi-Parting (Double leaf * 90° opening)	Single Leaf (Single leaf * 90° opening)	
Door Leaf Weight(kg) × Leaves	Standard	150×2	
	Heavy-Duty	(151-250)×2	
	Standard	1765 and above	
Unit Length (mm) (mm)	Inward opening type	Transformer external (controller concealed)	1560-1764
		Transformer and controller external	1295-1559
	Outward opening type	Standard	1880 and above
		Transformer external (controller concealed)	1675-1879
Transformer and controller external	1410-1674		
Single Leaf Area: D×W×DH (m <sup>2</sup> )	MAX 4.5		
Door Leaf Thickness:DT (mm)	44		
Function During Power Outage	Manual Open - Automatic Close		
Unit Dimensions	W940×H152×D148		
Unit Surface Color	Silver		
Average Opening/Closing Speed	~35 degrees/sec		
Required Power Supply Capacity	AC 220V·5A	AC 220V·2.5A	

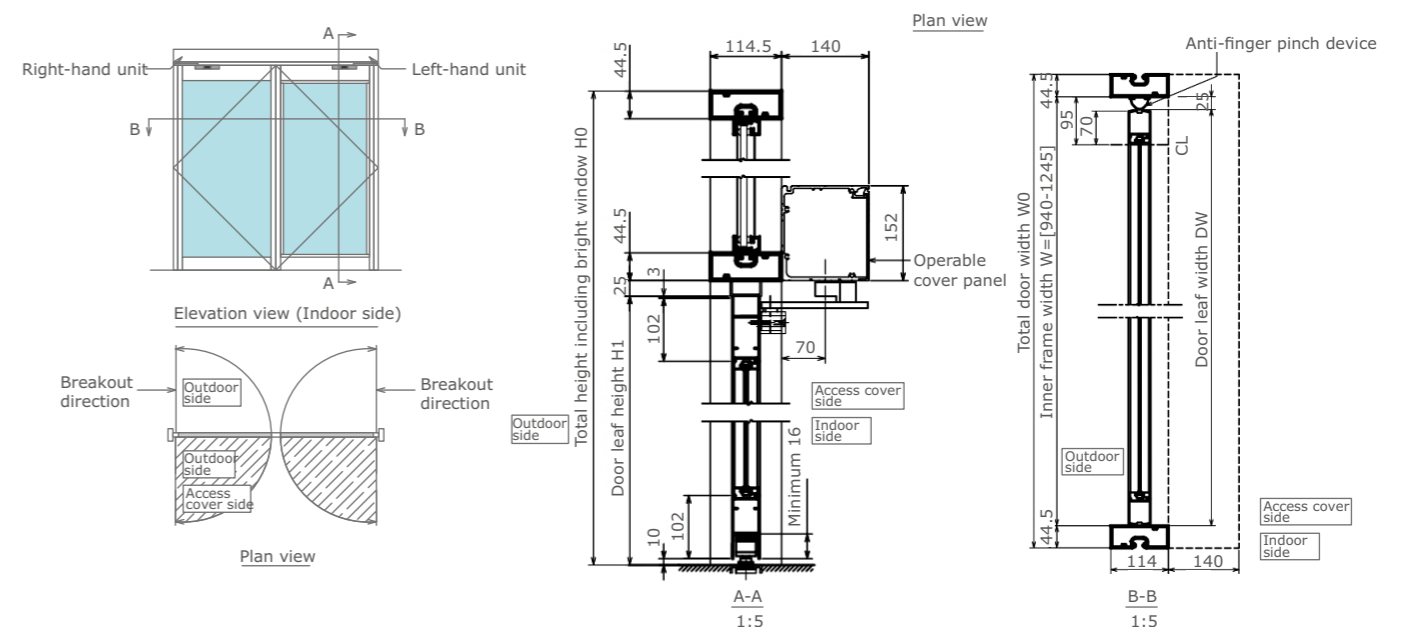

# GT-10 GT-20B



Surface Mounted Swing Door

# GT-660



外装型/内藏型平开自动门

## Product Features

- Suitable for both right-hand and left-hand units, offering multiple functions for ease of use.
- Diverse options provide customized automation solutions for customers.
- Electromechanical drive unit ensures quiet and smooth operation of the automatic door.
- Low-energy and full-power drive mechanisms available for various applications.
- Imported NABCO equipment from Switzerland, with high component consistency and reliability.
- Unique wind compensation feature ensures the automatic door remains fully open or fully closed in windy conditions.
- Dual certified to EN and TUV standards.

### GT10

Installation and assembly options

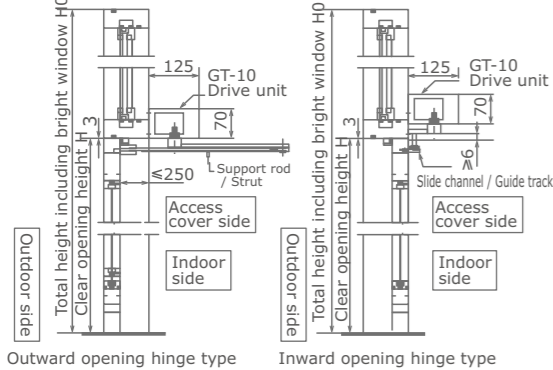

### GT20B

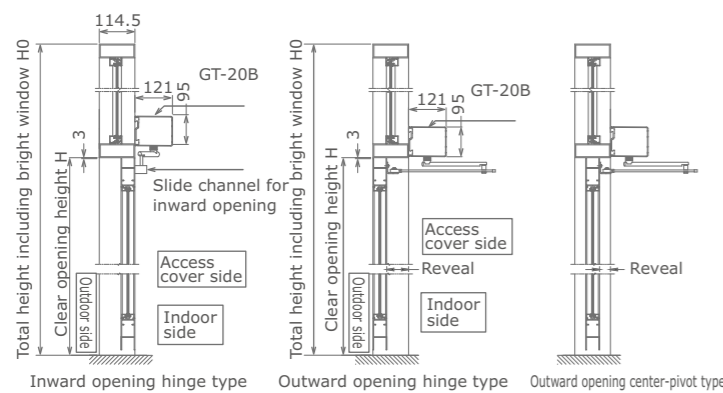

## Specifications

Drive Unit	GT-10	GT-20B
Door Opening Type	Single leaf * 105° opening	Single leaf * 90° opening
Door Leaf Weight × Leaves	150 kg×1	250 kg×1
Unit Length(mm)	730mm	689mm
Single Leaf Width:DW(mm)	730~1100mm(overhead installation) 800~1100mm(door leaf installation)	1200mm or less
Power Assist Function	Yes	
Function During Power Outage	Automatic close	
Unit Dimensions	W730×H70×D125	W689×H95×D121
Unit Surface Color	Silver	
Average Opening/Closing Speed	~35degrees/sec	
Power transmission	Standard Arm Sliding arm	
Required Power Supply Capacity	AC 220V·5A	AC95~ 260V ·5A
Motor Type	Commutator motor	
Motor Voltage	115V	
Header depth	Max 165Nm	
	Standard Rod max. 250 mm	
	Sliding rod pl -50/+150 mm ps -50/+150 mm	
Door Leaf Opening Angle	Max 105°	
Forced Closing Range (No Power)	≈10..15° non-adjustable	
Forced Closing Cushioning (No Power)	Infinitely adjustable (adjust with trimmer)	



The LCD screen integrated with the drive mechanism provides users with guidance for initial startup. No external equipment is required.



The lighting program selection button and main control switch are integrated into the side cover for intuitive operation.



Drive arm – Our automatic swing door drive unit, equipped with a drive arm and pushing function, is the most effective way to control NABCO swing door systems.



Slide channel – An automatic swing door drive unit with sliding arm and push/pull functions, representing the most common and aesthetically pleasing architectural solution.

## Product Features

- Maximum drive door leaf weight of 180kg. Utilizes vector control technology, permanent magnet synchronous motor, and high-grade magnets for greater output torque.
- Tested lifespan of over 500,000 cycles. High-precision bearings, alloy gears, and high-precision gear hobbing process for extended equipment service life.
- Mobile APP commissioning eliminates complex setup, making product installation and commissioning more convenient.
- Less than 50 decibels. Motor maximum speed of 300 rpm for ultra-quiet operation.
- 480×70×70mm(concealed type). The motor maintains a maximum speed of 300 rpm, eliminating the need for complex speed reduction design, resulting in a smaller footprint.
- Self-adaptive door leaf weight detection automatically adjusts torque to maintain stable door operation speed.
- Obstacle detection and reversal function: When the door encounters a person or other obstacle during operation, the door operator quickly detects the obstruction and reverses direction to ensure safety.

## Specifications

Item	GT-660
Door Opening Type	Single leaf * 90° opening
Door Leaf Weight × Leaves	180 kg×1
Unit Length (mm)	420mm
Single Leaf Width: DW (mm)	1200mm or less
Power Assist Function	No
Function During Power Outage	Cannot close automatically
Unit Dimensions	W420×H68.5×D84.5
Unit Surface Color	Silver
Average Opening/Closing Speed	~35degrees/sec
Required Power Supply Capacity	AC 100~220V·2.5A
Maximum Output Torque	75Nm
Manual Opening Force During Power Outage	<10N
Maximum Opening Angle	<110°
Noise Requirement	<50dB
Cycle Endurance	>50 cycles
Obstacle Detection Sensitivity	<100N (adjustable)
External Interface	Supports dry contact input for door contact, electric lock, microwave sensor, safety light curtain, etc.
Bi-Parting Interlock	Bi-parting opening mode can be set via interlock connection
Push-to-Hold-Open	Press and hold for 5 seconds when the door is in the fully open position, the door will remain open

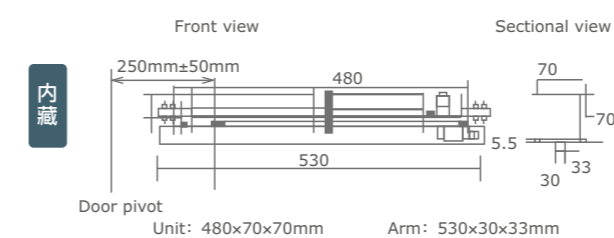
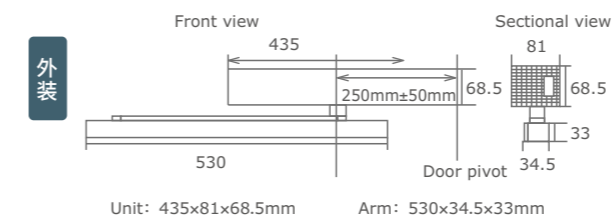
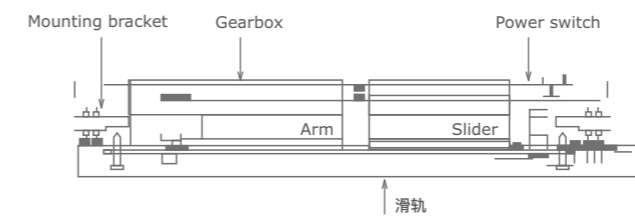

Surface mounted

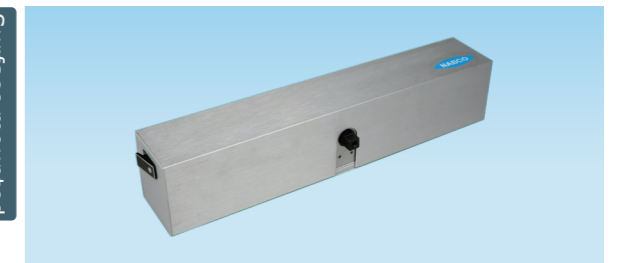

Concealed

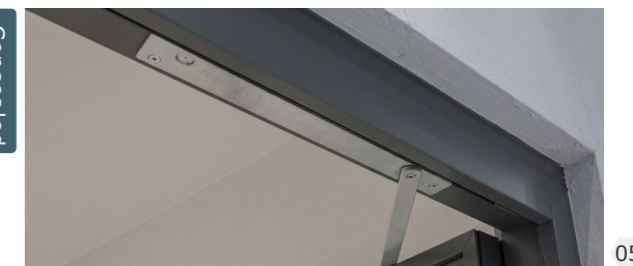

# GT-610 GT-620



Underground Concealed Swing Door

# GT-650



Overhead Concealed Swing Door

## Product Features

- Floor spring type swing door equipment, utilizing the output shaft of the floor-mounted motor to achieve automatic door opening and closing through lower drive.
- Opening/closing speed adjustable from 3-8 seconds.
- Hold-open time adjustable from 0-30 seconds.
- Mode selection: Power assist open, power assist close, magnetic lock, electric bolt lock.
- Five-position mode switch: Auto, Hold Open, Power Assist, Hold Closed, One-Way Passage.

## Specifications

Item	GT-610	GT-620
Door Opening Type	Single/Bi-Parting (90° opening)	
Door Leaf Weight × Leaves	150 kg×1	250kg×1
Unit Length (mm)	Max900mm	Max1200mm
Door Leaf Size	Customer supplied door leaf	
Function During Power Outage	Cannot close automatically	Cannot close automatically
Unit Dimensions	W108×H296×D146	W139×H358×D184
Controller Dimensions	W200×H80×D250	
Unit Weight	6.5kg	11.5kg
Average Opening/Closing Speed	~35 degrees/sec	~35degrees/sec
Required Power Supply Capacity	AC 220V·5A	AC 220V·5A
Shaft Distance	70mm	110mm
Maximum Output Torque	70Nm	120Nm
Maximum Power	35W	55W
Opening Angle	45~135° adjustable	
Protection Class	IP67	

## Swing door unit dimensions

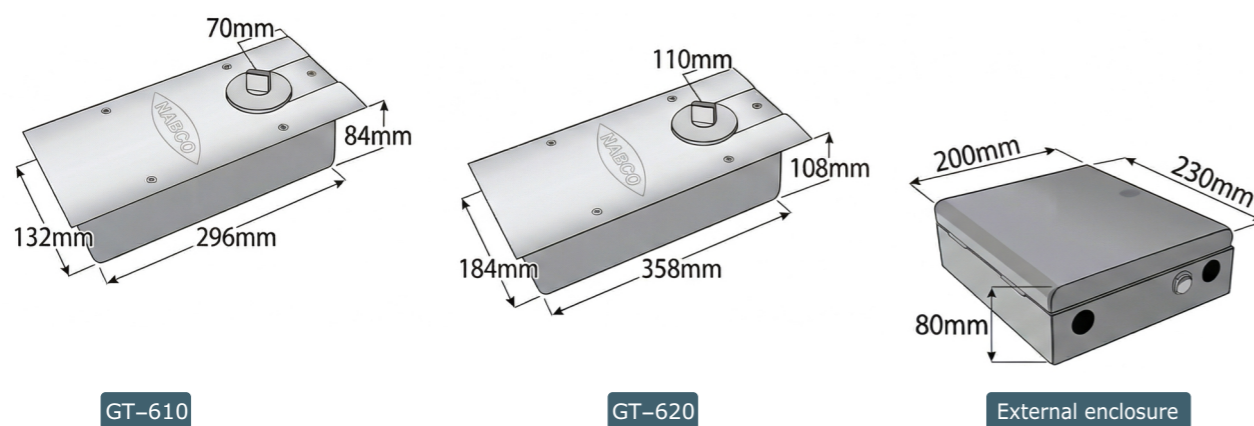

## Product Features

- Concealed swing door equipment. Hidden installation within the door frame header provides a sleek and minimalist overall appearance.
- Multiple modes available: Auto, One-Way Passage, Night, Wind-Resistant, Hold Open / Hold Closed.
- Features automatic fault detection and displays fault codes for easy installation and maintenance..

## Specifications

Item	GT650A	GT650B
Door Opening Type	Single Leaf (Single leaf * 90° opening)	Single Leaf (Single leaf * 90° opening)
Door Leaf Weight × Leaves	150 kg × 1 (Center-pivot door 200 kg × 1)	200 kg × 1 (Center-pivot door 300 kg × 1)
Single Leaf Area: DW×DH (m²)	1000mm (Center-pivot door 2000mm)	1100mm (Center-pivot door 3000mm)
Function During Power Outage	Cannot close automatically	
Unit Dimensions	W161×H80×D92	W180×H90×D155
Controller Dimensions	W355×H48×D29	
Unit Weight	2.5kg	4.5kg
Average Opening/Closing Speed	~35 degrees/sec	
Motor	24V Permanent Magnet Brushless DC	36V Permanent Magnet Brushless DC
Maximum Output Torque	45Nm	70Nm
Maximum Power	60W	80W
Standby Power	≤3W	

## Swing door unit

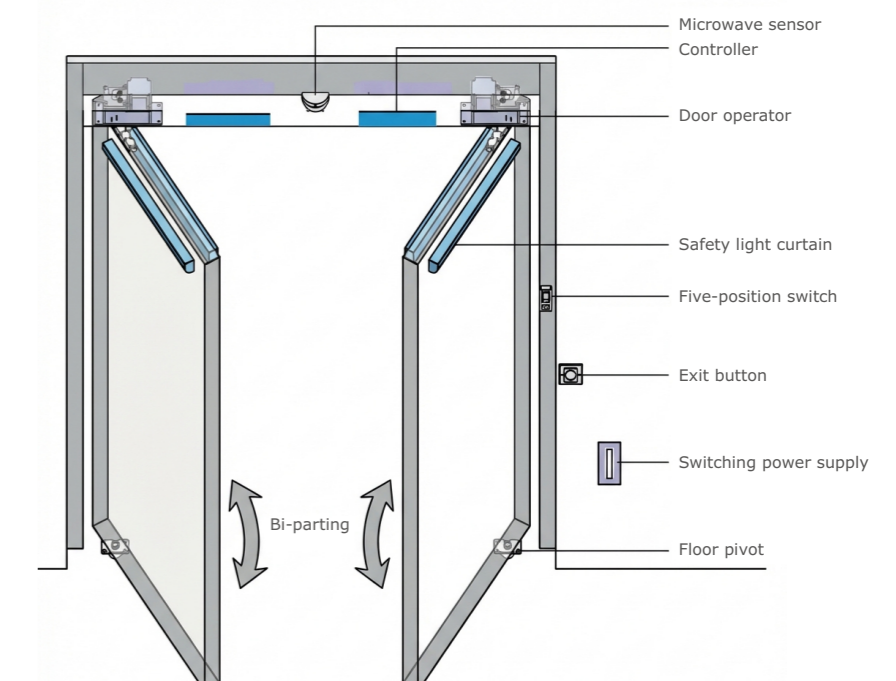

# GT-5

Manual Balance Door

# GT-8300BD

Automatic Balance Door

## Product Features

- The door leaf opening force is approximately half that of a standard manual door, making it easier to push, especially in windy locations.
- Balanced doors can replace floor spring doors. The door leaf can be positioned after opening 90 degrees, facilitating crowd evacuation.
- The door leaf opens in an elliptical path, minimizing space occupation.
- Structurally safe, significantly reducing the risk of injury from door leaf tipping caused by ground settlement.
- Flexible door leaf configurations; can be installed independently as building entrances or used with automatic doors.
- Various surface finishes available to meet diverse customer requirements.
- No floor grooving needed, simplifying on-site installation.

## Specifications

Balanced Door Type	Center-Pivot Type				Closer Type			
Door Opening Type	GT-Z 5150	GT-Z 5200	GT-Z 5400	GT-Z 5500	GT-B 5150	GT-B 5300	GT-B 5500	
Door Opening Type	Single/Bi-Parting (90° opening)							
Door Leaf Weight × Leaves	150 kg ×1	200 kg ×1	400 kg ×1	500 kg ×1	150 kg ×1	300 kg ×1	500 kg ×1	
Unit Length (mm)	Max 1800 for single leaf							
Max Door Leaf Width (mm)	Single Leaf	1100	1250	1500	1800	1100	1250	1800
	Bi-Parting	3000	4000	4500	4800	3000	4000	4800
Max Door Leaf Height (mm)	2200	2500	3000	3600	2200	2500	3600	
Min Door Leaf Width (mm)	760	760	900	900	900	900	900	
Single Leaf Area: DW×DH (m <sup>2</sup> )	MAX7.5							
Door Leaf Thickness: DT (mm)	50							
Door Edge Specification	65/100							
Function During Power Outage	Manual Open - Automatic Close Device							
Unit Surface Color	Fluorocarbon Coating / Stainless Steel							

## Center-Pivot Balanced Door GT-Z5

Suitable for public places with heavy traffic, venues, passages for people with disabilities, and standard exterior doors. Best for door openings with a minimum leaf width of 760mm, typically within a height of 4000mm and a single leaf width of 1200mm. Drive hardware is concealed with no exposed components, offering a light push force.

## Closer Type Balanced Door GT-B5

Suitable for public places with heavy traffic, venues, buildings with a stack effect, and areas prone to typhoons, wind, and snow. Standard exterior door with a minimum leaf width of 900mm. Best for door openings typically within a height of 4000mm and a single leaf width of 1200mm. Maximum door leaf weight up to 500KG.

Drive hardware is concealed, with the closer arm exposed at the top, offering a light push force. Level 1-6 force adjustment, three-stage speed adjustment, equipped with a cushioning function to reduce injury risk in strong wind conditions.

## Product Features

- Dynamic Balanced Drive System**  
Equipped with a GT-8300 high-precision drive module utilizing vector control technology, achieving a constant opening speed of 35 degrees/sec (±1 degree/sec accuracy). Compared to traditional automatic doors, it offers lower energy consumption and reduced noise.
- Dual-Mode Intelligent Switching**
  - Electric Mode:** Supports various activation methods such as radar, infrared, and facial recognition with a fast response time.
  - Manual Mode:** Automatically switches during power outages or malfunctions; manual opening force required by a single person is ≤30N (approx. 3kg), compliant with fire emergency egress requirements.
  - Emergency Mode:** Automatically maintains an open state upon fire alarm signal activation, ensuring rapid occupant evacuation.
- Innovative Structural Design**  
Exposed pivot / concealed pivot dual choice.

## Specifications

Item	GT-8300BD	
Door Opening Type	Bi-Parting (Double leaf * 90° opening)	Single Leaf (Single leaf * 90° opening)
Door Leaf Weight × Leaves	400 kg×2	400 kg×1
Single Leaf Area: DW×DH (m <sup>2</sup> )	MAX7.5	
Max Door Leaf Width (mm)	Single Leaf	1500
	Bi-Parting	3000
Max Door Leaf Height (mm)	5000mm	
Min Door Leaf Width (mm)	900mm	
Door Leaf Thickness: DT (mm)	70/50	
Door Edge Specification	82/55/35( )	
Function During Power Outage	Manual Open - Automatic Close Device	
Unit Dimensions	Unit Cross Section: H160×D152	
Unit Surface Color	Fluorocarbon Coating / Stainless Steel	
Average Opening/Closing Speed	~35 degrees/sec	
Required Power Supply Capacity	AC 220V·5A	AC 220V·2.5A
	Brushed motor with encoder	
Equipment Specification	Rated power: 70W, torque: 89Nm (depending on door weight/configuration)	
Controller	12VDC, 750mA, OPUS controller	
Drive Method	Transmission arm drive	
Operating Wind Speed	15m/s or less	

The maximum allowable weight and fabrication range of the door leaf are related to the door side profile specifications. Please refer to NAB25SP0005\_001\_GT-8300BD Electric Balanced Door Standard Specification for details.

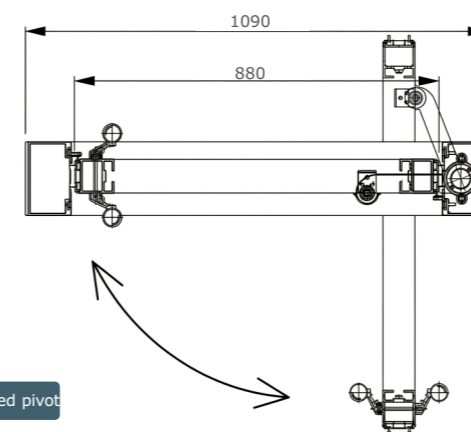
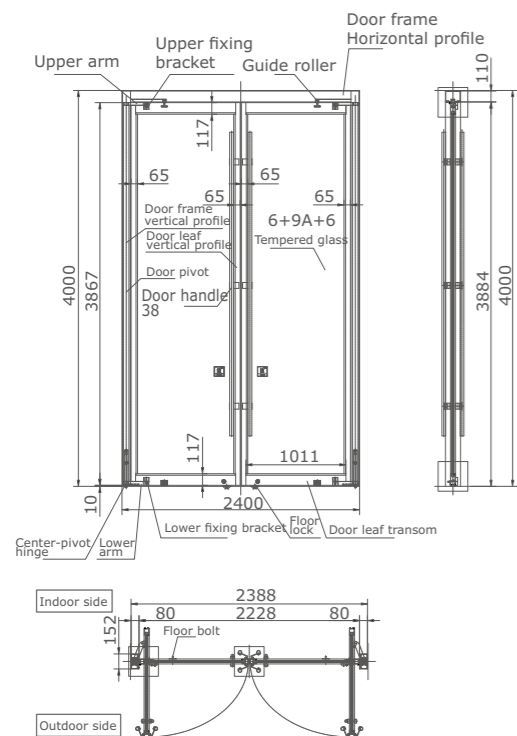

Concealed pivot  
Left-hand door

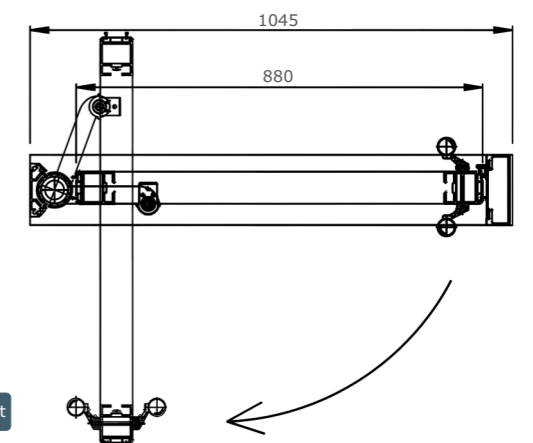

Exposed pivot  
Right-hand door

**M-01169 Program Switch**

A swing door program switch that combines ease of operation with device security.

ON	When in the ON position, the LCD screen is operable.
OFF	When in the OFF position, the LCD screen is non-operable. When in the OFF position, the main power supply to the LCD screen unit is not cut
HOLD OPEN	As long as the switch is in the HOLD OPEN position, the door remains open. The door should be kept open in this manner. Do not use any objects to prop the door open.



**NS-A01 Infrared Sensor**

An auto door sensor that combines Japanese technology with safety, security, and comfort.

Detection Method	Near-infrared reflection method (dynamic and static sensing)
Maximum Installation Height	4.0m
Maximum Detection Area	5.2m wide x 3.3m deep (reference value)
Power Consumption	DC12V 120mA or less
Remarks	Independent area setting, suitable for irregularly shaped doors. Features self-diagnosis, non-contact sensing function. Includes snow and insect protection measures, and eco-friendly mode.



**NH-201 Active Infrared Safety Sensor**

Features an adjustable detection area, anti-masking function, and easy configuration via DIP switches, providing safety protection for pedestrians in low-power automatic door applications.

Technology	Active Infrared Background Suppression
Detection Range	0.7m to 2.5m (adjustable via knob)
Dimensions (L×H×W)	340-700-900mm x 43.5mm x 47.5mm
Material	Aluminum, ABS, and resin glass
Color	Black or silver Front end black
Compliant Standards	EMC 2004/108/EC; MD 2006/42/EC; EN 12978 EN ISO 13849-1:2008 Performance level c> CAT.2



**NH-221 Laser Safety Sensor**

Leveraging Time-of-Flight technology, it provides comprehensive safety protection for swing doors. Features include resistance to environmental interference, anti-pinch zone protection, door edge safety protection, simple installation, small blind spot, compact size, parameter adjustment via DIP switches, and support for self-learning functionality.

Technology	Laser scanner, Time-of-Flight measurement
Detection Range	4m (diagonal), reflectivity 2% (i.e., max. 3.7m at width 1.5m)
Dimensions (L×D×H)	142mm × 85mm × 23mm (mounting base +7mm)
Material / Color	PC/ASA - Black - Silver - White
Supply Voltage	12-24V DC 15%
Power Consumption	≤2W



**Office Building**

**Xiong'an Sinochem Building**

Manual Balance Door



**Tianjin First Center**  
Overhead Concealed Heavy Duty Swing Door

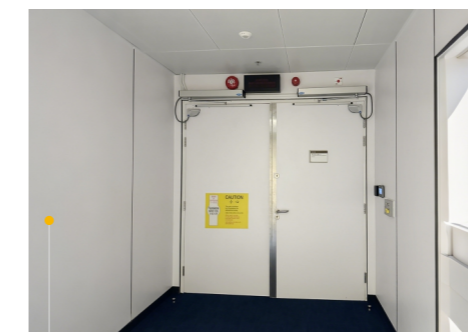

**Hong Kong Tseung Kwan O...**  
Surface Mounted Swing Door GT-10

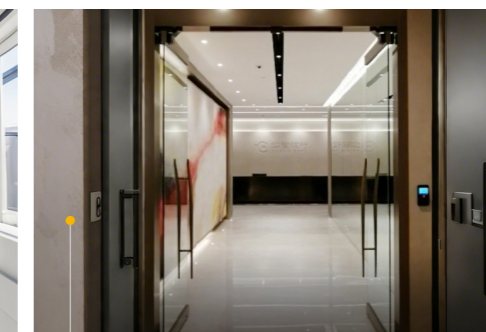

**Hua Xia Bank**  
Overhead Concealed Heavy Duty Swing Door GT-8300

# Project References

## Hotel



Macau Morpheus Hotel  
Underground Concealed Swing Door\_GT-610

## Shopping Mall



PARKnSHOP Hong Kong  
Surface Mounted Swing Door  
\_GT-10



Hong Kong ICC  
Underground Concealed Swing Door\_GT-620

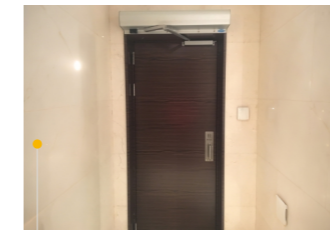

Beijing Tianyuangang Center  
Swing Door\_GT-710

## Hospital



Beijing Hospital  
Heavy Duty Swing Door  
GT-8400

Peking University Third  
Hospital  
Heavy Duty Swing Door  
\_GT-8400

Ningxia Baofeng Hospital  
Swing Door\_GT-710

Swing Door\_GT-710



Zhonghai Times Square  
Manual Balance Door

# Project References

## Residence



Qiantan Mansion  
Underground Concealed Swing Door\_GT-610



Hong Kong Coastal Skyline  
Surface Mounted Swing Door\_GT-10



Qiantan Runjing  
Overhead Concealed Swing Door\_GT-660

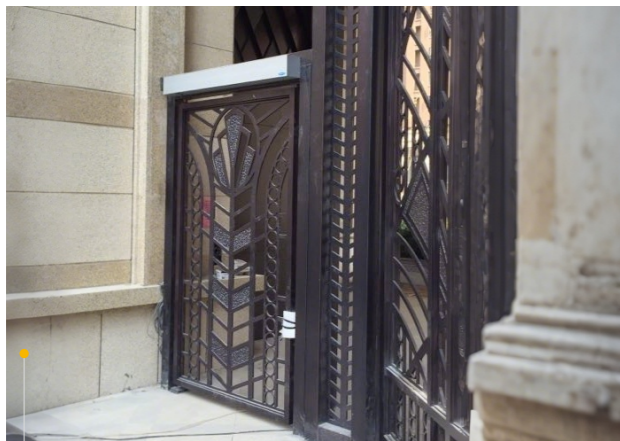

Zhengzhou Langyue  
Heavy Duty Swing Door\_GT-8400



Overhead Concealed Swing Door\_GT-650



Shanghai ITG Luyuan  
Heavy Duty Swing Door\_GT-8300



Fuzhou Xiangkai Changlong Apartment Community  
Underground Concealed Swing Door\_GT-610



Jinan Poly Yanlord Real Estate  
Heavy Duty Swing Door\_GT-8300

# Operation and Maintenance

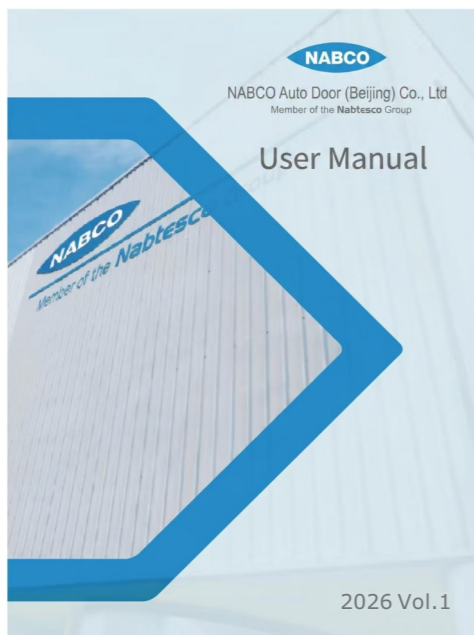

NABCO automatic doors and sensors are developed and designed with the basic concept of "human safety and comfort", but unexpected accidents can also occur if not used properly.

In order to ensure the safety and comfortable use of automatic door device, please read the product instructions carefully before using the device. We hope it will become your eternal companion in the life.

## To Property Management Staff

To remind pedestrians of safety precautions, please assist us in posting the Automatic Door Signs and Warning Signs on the automatic doors.



Warning Signs

Automatic Door Signs

## Please install the auxiliary sensors

The control system properly controls the operation of the automatic door through the coordination of the activation sensor and the auxiliary sensing device. The Japan Automatic Door Association clearly states in its Safety Guidelines: "To ensure the safety of pedestrians, auxiliary sensors must be installed." Nabco includes automatic door auxiliary sensors as standard equipment across all its product lines.

Your understanding in the design and purchase of this product is appreciated.

# History

## Development History

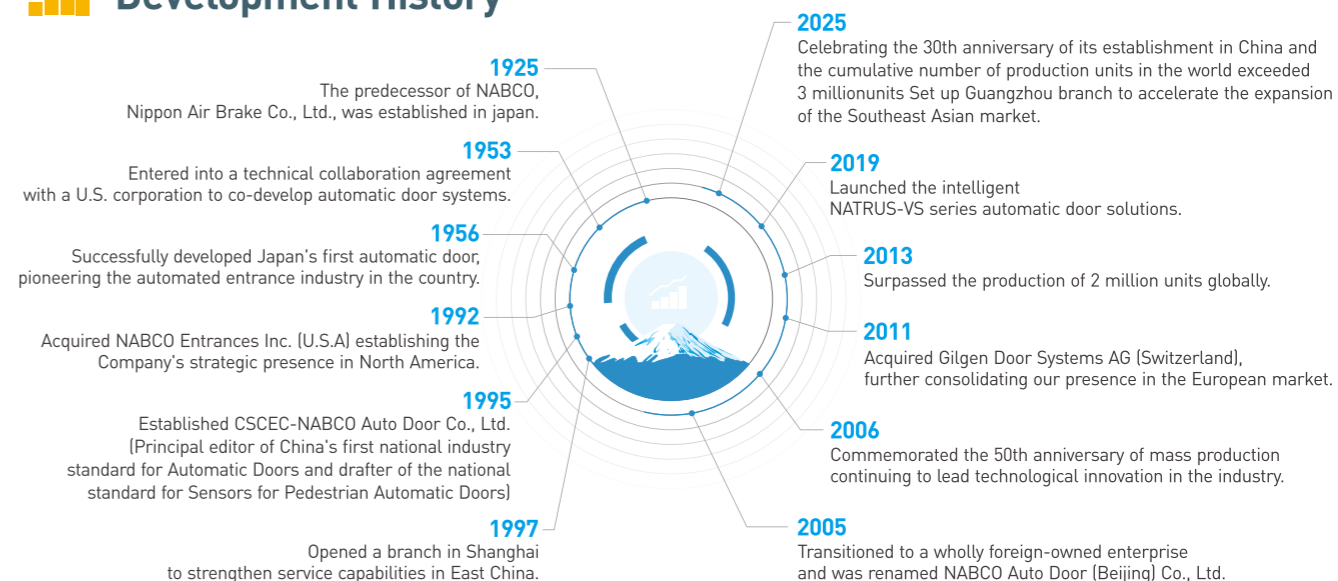

## Company Profile of NABCO

NABCO manufactured the first automatic door in Japan and is now the major automatic door manufacturer in the world. NABCO has No.1 market share approximately 50% in Japan over the years.

Since NABCO manufactured the first automatic door in Japan in the 1950s, NABCO have developed a vast range of products for different applications and provided best services to our customers, which has made NABCO the "OnlyOne" automatic door solution provider.

## Global Business

NABCO is a global automatic door enterprise that manufacture and sell automatic doors with Asian network and 3 subsidiaries, NABCO Entrances Inc. in North America, Gilgen Door System AG in Switzerland and NABCO Auto Door (Beijing)Co., Ltd. in China.



## Notes for Using Automatic Doors

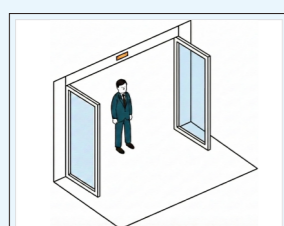

### 1 Please don't stop at the door

Because it is not easy to detect the presence of someone between the door bodies, the door body may be improperly closed due to the sensor judgment error, thus resulting to pinching accident. Therefore, don't stand and talk in the doorway.

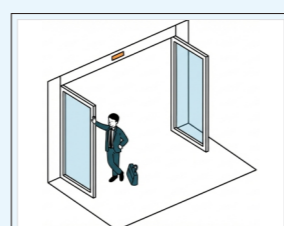

### 4 Please don't hold the door with hand

Please don't lean on the door or pull the door with your foot. Your hand is easy to be pinched at the door edge and corner during door opening and closing. Please be careful.

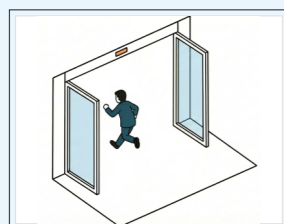

### 2 Please don't enter the door quickly

The sensors can sense the presence of person, but cannot immediately make the door open. Don't thrust yourself in before the door is fully open or when the door is in the process of closing.



### 5 Please don't play at the door

Children always feel that the door opening and closing is interesting, so they play nearby. Once their hands are pinched by the door, it is very dangerous. Please remind them timely if you find any children playing nearby the door.



### 3 Please don't enter the door from diagonal direction

The oblique plane and side plane of the door body are the dead angles of sensor, which may cause people to collide with the door body due to the slow opening and closing of the door body. Therefore, please pass the automatic door from the front.

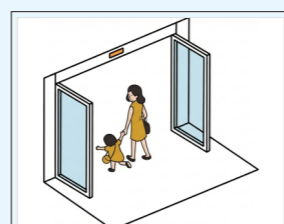

### 6 Please help people in need

Adults should hold their hands when children pass through automatic doors. When the elderly and disabled passthrough the door, people around should take the initiative to help them.